

REVISED 7/1/19

**PRODUCT**

JOULLE SCONCE  
JOULLE WALL 06-001

**MATERIALS (FINISHES)**

ANODIZED ALUMINUM (AGED  
BRONZE, GOLDEN BRASS, SATIN  
BLACK, SATIN SILVER)

SOLID OPTIC CRYSTAL (CLEAR,  
FROSTED, SMOKE)

**WEIGHT**

4.4 LBS

**LAMPING**

INTEGRATED LED (QTY 6)  
13W, 3000K  
ELV AND PHASE DIMMABLE

**CERTIFICATIONS**

ETL LISTED (120V, US/CANADA)  
PENDING

**NOTES**

JOULLE IS COMPRISED OF  
MODULAR COMPONENTS AND IS  
MEANT TO BE ASSEMBLED ON-  
SITE BY A QUALIFIED AND  
LICENSED ELECTRICIAN AND  
INSTALLATION PROFESSIONAL.

PATENT PENDING



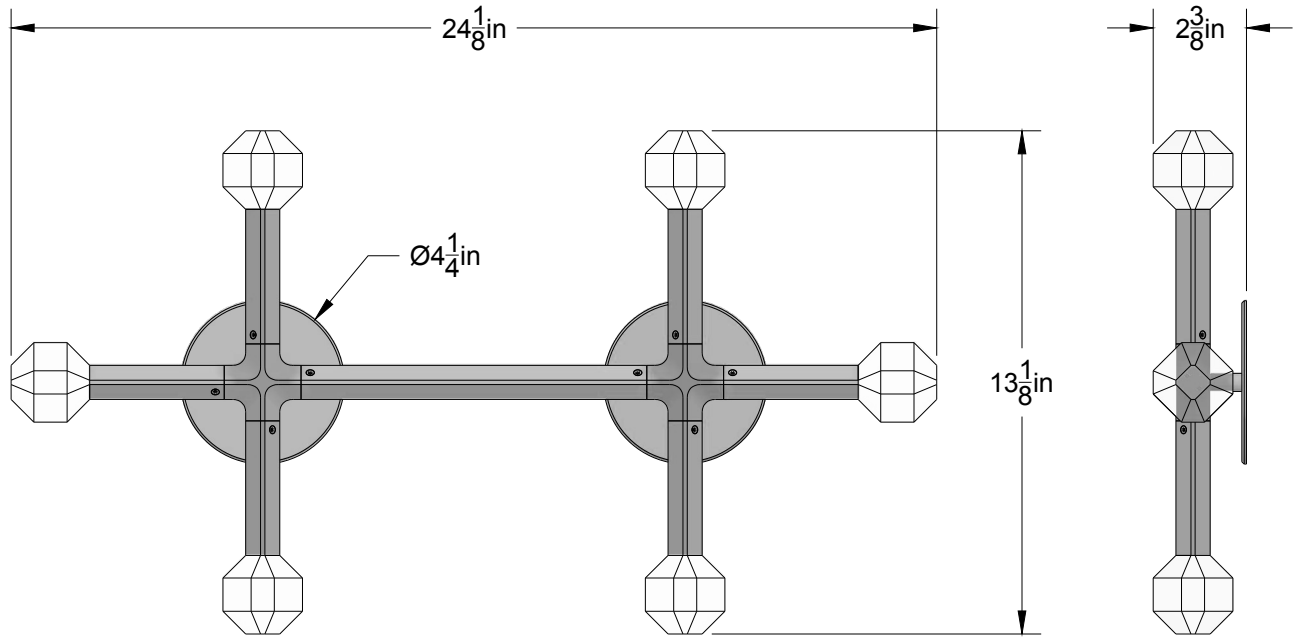

ELEVATION VIEW

SIDE VIEW

© 2019, LAKE AND WELLS, LLC. ALL RIGHTS RESERVED