

REVISED 7/1/19

**PRODUCT**

JAX SCONCE  
JAX WALL 08-001

**MATERIALS (FINISHES)**

ANODIZED ALUMINUM (AGED  
BRONZE, GOLDEN BRASS, SATIN  
BLACK, SATIN SILVER)

SOLID OPTIC CRYSTAL (CLEAR,  
FROSTED, SMOKE)

**WEIGHT**

3.7 LBS

**LAMPING**

INTEGRATED LED (QTY 8)  
13W, 3000K  
ELV AND PHASE DIMMABLE

**CERTIFICATIONS**

ETL LISTED (120V)

**NOTES**

JAX IS COMPRISED OF MODULAR  
COMPONENTS AND IS MEANT TO  
BE ASSEMBLED ON-SITE BY A  
QUALIFIED AND LICENSED  
ELECTRICIAN AND INSTALLATION  
PROFESSIONAL.

PATENT PENDING



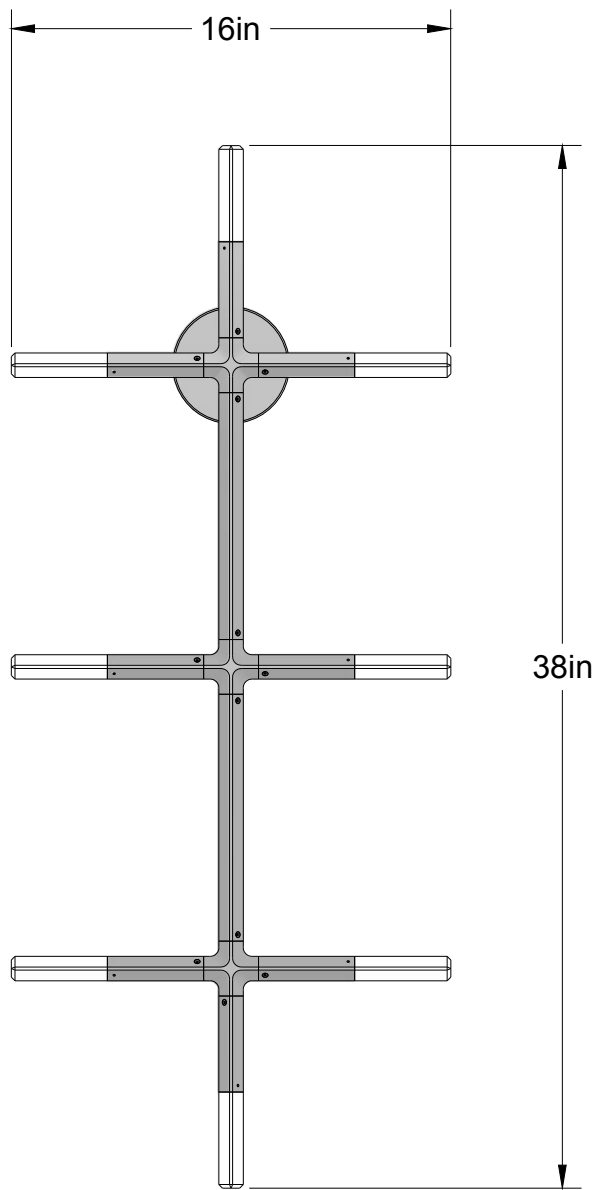

ELEVATION VIEW

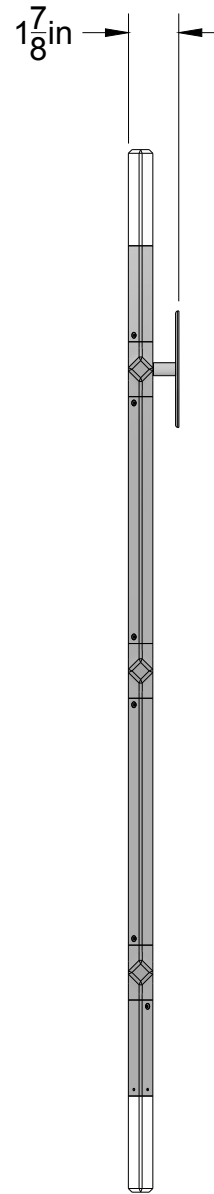

SIDE VIEW

© 2019, LAKE AND WELLS, LLC ALL RIGHTS RESERVED