



REVISED 6/1/19

**PRODUCT**

JAX CHANDELIER  
JAX 15-003

**MATERIALS (FINISHES)**

ANODIZED ALUMINUM (AGED  
BRONZE, GOLDEN BRASS, SATIN  
BLACK, SATIN SILVER)

SOLID OPTIC CRYSTAL (CLEAR,  
FROSTED, SMOKE)

**WEIGHT**

9,2 LBS

**LAMPING**

INTEGRATED LED (QTY 15)  
1,3W, 3000K  
ELV AND PHASE DIMMABLE

**CERTIFICATIONS**

ETL LISTED (120V)

**NOTES**

JAX IS COMPRISED OF MODULAR  
COMPONENTS AND IS MEANT TO  
BE ASSEMBLED ON-SITE BY A  
QUALIFIED ELECTRICIAN AND  
INSTALLATION PROFESSIONAL.

*PATENT PENDING*



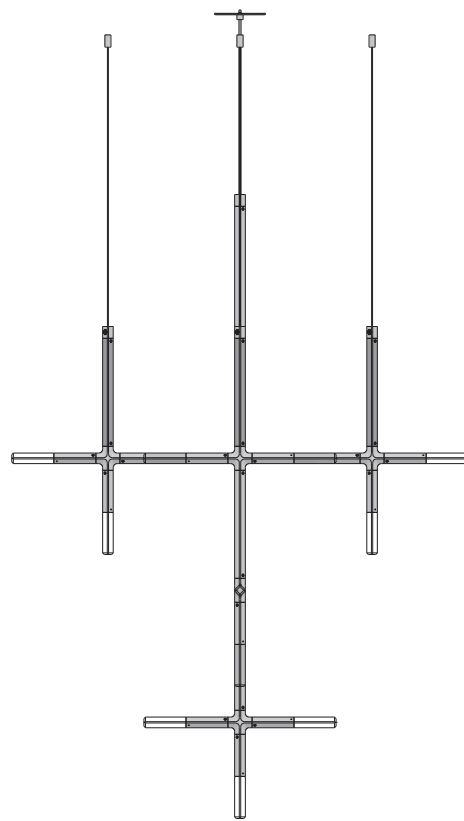
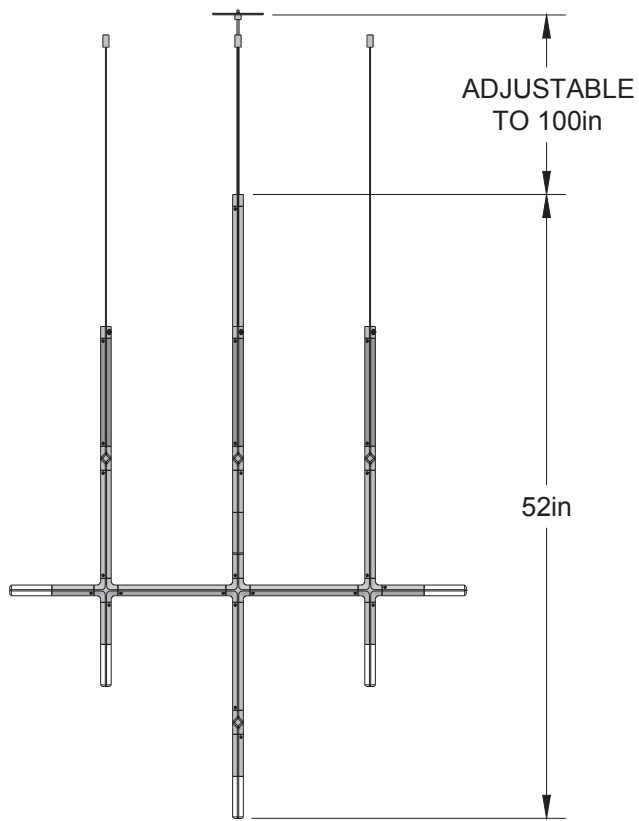
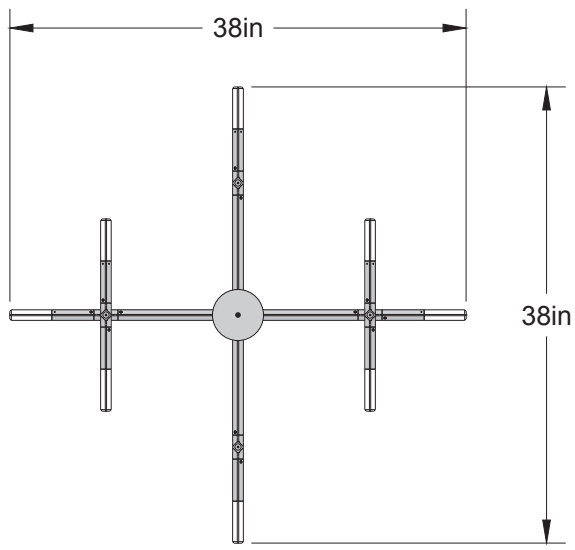

© 2019, LAKE AND WELLS, LLC ALL RIGHTS RESERVED